

CITY OF PAINESVILLE

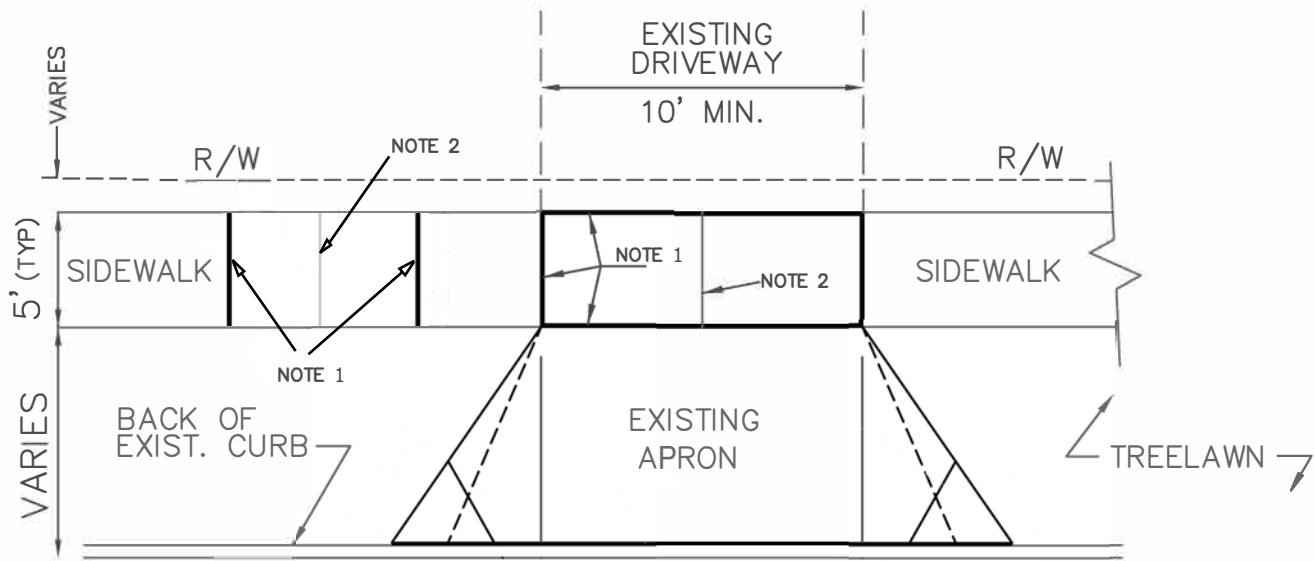

CONCRETE SIDEWALK PLAN DETAIL

- 1) 1/2" ODOT 705.03 EXPANSION MATERIAL.
- 2) CONTROL JOINTS SHALL BE INSTALLED TO A DEPTH AS CALCULATED BY THE FORMULA "T/4" WHERE "T" REPRESENTS ANY SLAB THICKNESS IN INCHES:
 $4\frac{1}{4} = 1"$ DEEP JOINT $6\frac{1}{4} = 1\text{-}1\frac{1}{2}"$ DEEP JOINT $8\frac{1}{4} = 2"$ DEEP JOINT
- 3) ALL CONCRETE SIDEWALKS SHALL BE ODOT CLASS C (4000 PSI) MINIMUM AND SHALL BE A MINIMUM FOUR (4) INCHES THICK, SIX (6) INCHES THICK WHERE THE SIDEWALK PORTIONS ARE THROUGH RESIDENTIAL DRIVEWAYS, OR EIGHT (8) INCHES THICK WHERE THE SIDEWALK PORTIONS ARE THROUGH COMMERCIAL/INDUSTRIAL DRIVEWAYS.
- 4) WIRE MESH OR FIBER MESH SHALL BE USED FOR CONCRETE REINFORCEMENT IN SIDEWALK PORTIONS THAT ARE THROUGH DRIVEWAYS.
- 5) FOUR (4) INCHES OF ODOT 304 OR #57 COMPACTED LIMESTONE, NON-RECYCLED SUBBASE IS REQUIRED, AS DIRECTED BY THE CITY ENGINEER.
- 6) ALL WORK PRIOR TO CONCRETE POUR MUST BE INSPECTED AND APPROVED BY THE CITY ENGINEER OR REPRESENTATIVE (FORMS, REINFORCEMENT, SUBBASE, AND LOCATION).

**CONCRETE SIDEWALK
REPLACEMENT**

CITY OF PAINESVILLE

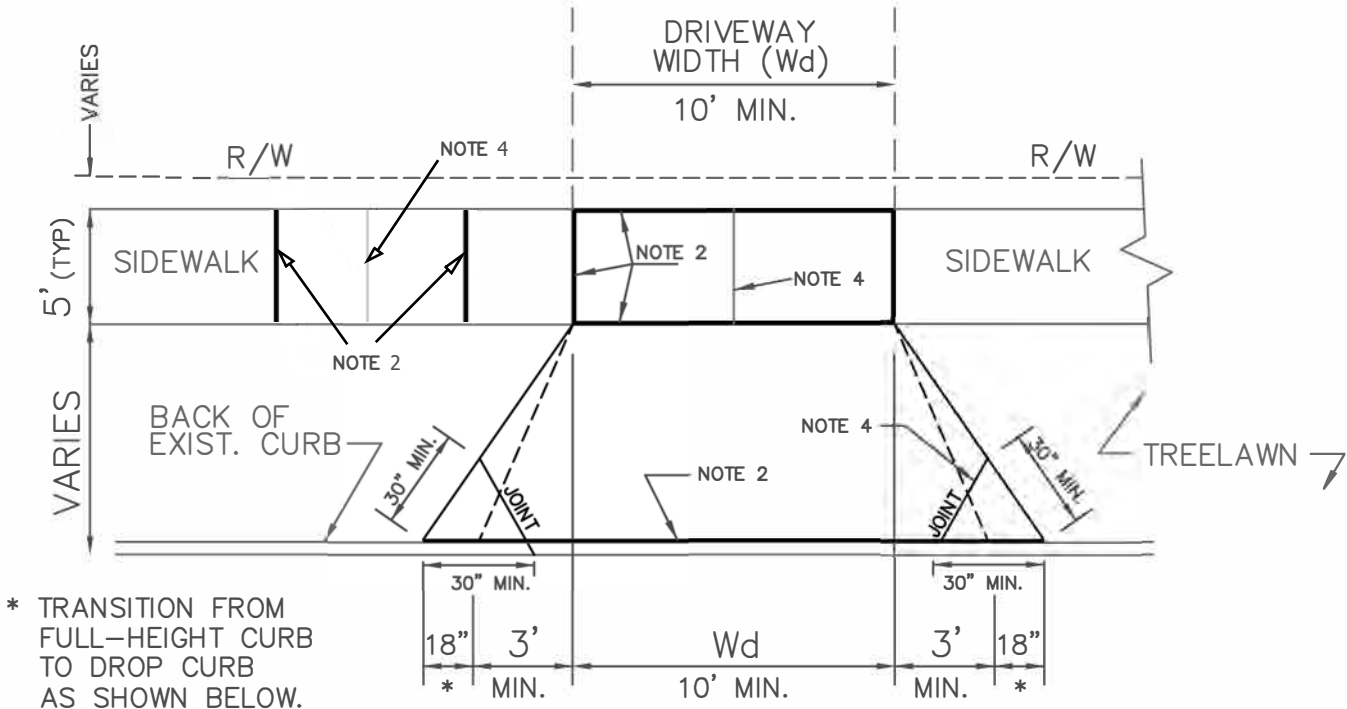

CONCRETE APRON PLAN DETAIL

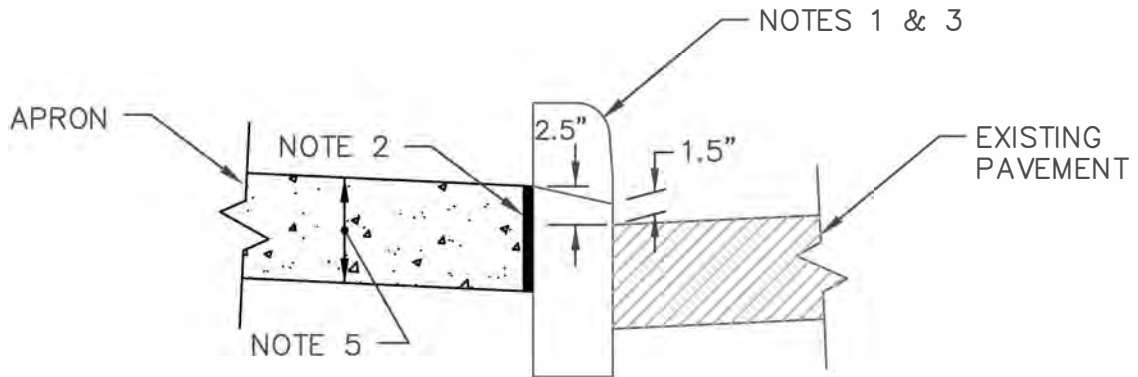

DROP CURB DETAIL

- 1) EXISTING CURBS SHALL BE HORIZONTALLY SAW-CUT AS SHOWN.
- 2) 1/2" ODOT 705.03 EXPANSION MATERIAL.
- 3) THE TRANSITION FROM STANDARD VERTICAL CURB SECTION TO DROP CURB SECTION IS TO BE WITHIN A **MINIMUM** OF 18" OF THE DRIVEWAY THROAT.
- 4) CONTROL JOINTS SHALL BE INSTALLED TO A DEPTH AS CALCULATED BY THE FORMULA "T/4" WHERE "T" REPRESENTS ANY SLAB THICKNESS IN INCHES:
 $4\frac{3}{4}=1\frac{1}{2}$ " DEEP JOINT $6\frac{3}{4} = 1\text{-}1\frac{1}{2}$ " DEEP JOINT $8\frac{3}{4} = 2$ " DEEP JOINT
- 5) ALL CONCRETE SHALL BE ODOT CLASS C (4000 PSI) MIN. AND SHALL BE SIX (6) INCHES THICK IN RESIDENTIAL AREAS AND EIGHT (8) INCHES THICK IN COMMERCIAL/INDUSTRIAL AREAS.
- 6) WIRE MESH OR FIBER MESH SHALL BE USED FOR CONCRETE REINFORCEMENT.
- 7) FOUR (4) INCH ODOT 304 OR #57 COMPACTED LIMESTONE, NON-RECYCLED SUBBASE IS REQUIRED, AS DIRECTED BY THE CITY ENGINEER.
- 8) ALL WORK PRIOR TO CONCRETE POUR MUST BE INSPECTED AND APPROVED BY THE CITY ENGINEER OR REPRESENTATIVE(FORMS, REINFORCEMENT, SUBBASE, AND LOCATION.)

DRIVEWAY APRON ON A CURBED PAVEMENT

CITY OF PAINESVILLE

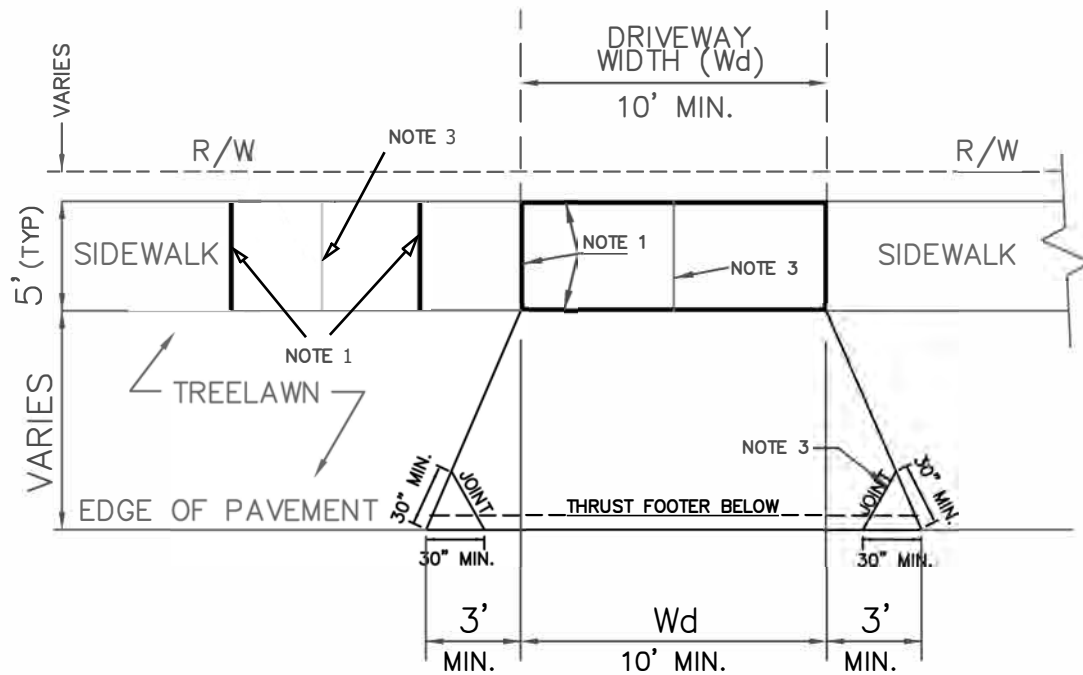

CONCRETE APRON PLAN DETAIL

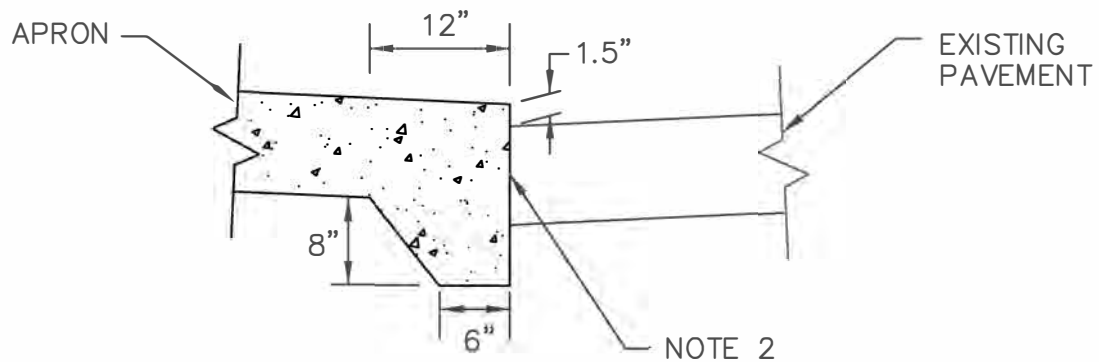

APRON SECTION DETAIL AT EDGE OF PAVEMENT

- 1) 1/2" ODOT 705.03 EXPANSION MATERIAL.
- 2) FULL-DEPTH PAVEMENT SAW-CUT.
- 3) CONTROL JOINTS SHALL BE INSTALLED TO A DEPTH AS CALCULATED BY THE FORMULA "T/4" WHERE "T" REPRESENTS ANY SLAB THICKNESS IN INCHES:
 $4\frac{1}{4} = 1"$ DEEP JOINT $6\frac{1}{4} = 1\text{-}1\frac{1}{2}"$ DEEP JOINT $8\frac{1}{4} = 2"$ DEEP JOINT
- 4) ALL CONCRETE SHALL BE ODOT CLASS C (4000 PSI) MIN. AND SHALL BE SIX (6) INCHES THICK IN RESIDENTIAL AREAS AND EIGHT (8) INCHES THICK IN COMMERCIAL/INDUSTRIAL AREAS.
- 5) WIRE MESH OR FIBER MESH SHALL BE USED FOR CONCRETE REINFORCEMENT.
- 6) FOUR (4) INCH ODOT 304 OR #57 COMPACTED LIMESTONE, NON-RECYCLED SUBBASE IS REQUIRED, AS DIRECTED BY THE CITY ENGINEER.
- 7) ALL WORK PRIOR TO CONCRETE POUR MUST BE INSPECTED AND APPROVED BY THE CITY ENGINEER OR REPRESENTATIVE (FORMS, REINFORCEMENT, SUBBASE, AND LOCATION.)

**DRIVEWAY APRON ON
AN UNCURBED PAVEMENT**